



Two-phase Digital Stepper Motor Driver SD-20403

Product Codes: 001700

Low Vibration

Low Noise

Low Power

Characteristics

- ◆ 32-bit DSP digital control mode
- ◆ Low vibration. low noise. low power
- ◆ Flexible micro-stepping, runs more smoothly
- ◆ Automatic memory function in the power failure
- ◆ Input signal photoelectric isolation
- ◆ Space-vector bipolar constant current
- ◆ Maximum output current is 2.6A
- ◆ Provide energy saving and automatic half-current lock feature
- ◆ Maximum 25600 steps/ rev and 16 kinds micro-stepping model
- ◆ Adapted to a total of Yang and single pulse mode
- ◆ CE



Performance Index

Electric Property (ambient temperature $T_j=25^{\circ}\text{C}$)

Power Supply	12V~ 40VDC, capacity 0.1KVA
Output Current	Peak current is 2.6 A (Max) (the output current can be set by panel dial switch
Drive Mode	Space-vector bipolar constant current
Exciting Type	200 steps/rev, 400 steps/rev, 800 steps/rev, 1000 steps/rev, 1600 steps/rev, 2000 steps/rev, 3200 steps/rev, 4000 steps/rev, 5000 steps/rev, 6400 steps/rev, 8000 steps/rev, 10000 steps/rev, 12800 steps/rev, 20000 steps/rev, 25000 steps/rev, 25600 steps/rev
Insulation Resistance	At normal temperatures and pressures > 100MΩ
Insulation Strength	At normal temperatures and pressures 0.5KV, 1Min

Ambient Temperature and parameters

Cooling Model	Natural convection (the drive is installed in the metal surface with a good thermal conductivity)	
Ambient Temperature	condition	Avoid dust, oil mist and corrosive gases
	Temperature	-5°C~ +40°C
	Humidity	<80%RH, no condensation, no frosting
	Vibration	5.9m/s ² Max

Storage Temperature	Temperature	-40°C~ +55°C
	Humidity	<93%RH, no condensation, no frosting
Dimension		92×55×21mm
Weight		0.2Kg

Functions and Operation

◆ Outstanding feature

Using 32-bit DSP all digital control mode, advanced space vector algorithm to optimize low-vibration and high-speed performance, and realize adaptive matching and optimizing control approach of a variety of motor, software update and easily upgrading.

Using micro-stepping algorithm to make the motor maintain optimal running performance whatever the drive set which subdivision and greatly improve the smooth and noise under low subdivision. Even if the user can not use the higher subdivision options due to the limit of control system output pulse frequency , can also get both of low-speed stability and high-speed, thereby reducing the requirements of control system, and help to reduce the overall cost of the system to improve performance.

◆ Power Supply

The drive internal switching power supply design can adapt to a wide voltage range. Users can choose 12V~40VDC depending on each situation. Capacity relates with the matching motor and setting current magnitude. Generally the higher rated supply voltage is conducive to improve high-speed torque of the motor, but it will increase the loss and temperature of the drive. The power supply must be noted the polarity, avoid reverse.

◆ Micro-step selection

Users can select 16 kinds of micro-step models by the drive panel SW1, SW2, SW3, SW4 four dial switch. It provides common two-phase step and five-phase step. (see the micro-step selection table)

Note: if users change the micro-step model, the drive takes effect after power on again.

SW1	SW2	SW3	SW4	Steps/rev	SW1	SW2	SW3	SW4	Steps/rev
ON	ON	ON	ON	25000	OFF	OFF	ON	OFF	25600
OFF	ON	ON	ON	20000	ON	ON	OFF	OFF	12800
ON	ON	ON	OFF	10000	OFF	ON	OFF	OFF	6400
ON	OFF	ON	ON	8000	OFF	ON	OFF	ON	3200
OFF	ON	ON	OFF	5000	ON	OFF	OFF	OFF	1600
OFF	OFF	ON	ON	4000	ON	OFF	OFF	ON	800
ON	ON	OFF	ON	2000	OFF	OFF	OFF	ON	400
ON	OFF	ON	OFF	1000	OFF	OFF	OFF	OFF	200

◆ Output Current Selection

The drive uses bipolar constant current model. The maximum output current value is 2.6A (peak). You can easily choose eight current values from 0.5A to 2.6A through different combinations of three switches on the side plate of the drive SW5, SW6 and SW7. (see the current selection table)

Note: if users change output current , the drive takes effect after power on again.

SW5	SW6	SW7	Current
OFF	OFF	OFF	0.5A
ON	OFF	OFF	0.8A
OFF	ON	OFF	1.2A
ON	ON	OFF	1.5A
OFF	OFF	ON	1.8A
ON	OFF	ON	2.1A
OFF	ON	ON	2.4A
ON	ON	ON	2.6A

◆ Self-test mode Switch

Users can choose on and off of the self-test model through 8th dial switch on the drive panel. When the self-test mode is open, the drive will observe the motor parameters before power on, and automatically finding the optimal control parameters. When self-test function is close, the drive will use the last testing motor parameter to work. So when the user firstly use drive and motor, you should adopt the self-test mode, then set the switch ' OFF ' to lock the current parameters and self-test optimization again after work station changed.

◆ Mono-pulse mode

The drive supports the standard single-pulse mode. The stepping pulse is form the pulse interface, by the direction of the port level determines the level of the direction of the motor.

Note: the drive power-on reset need 10 seconds, and then take effect after 5 seconds.

◆ Automatic half current

The drive will be in the half current state after working about 0.1 seconds and not receiving new pulse. Phase current is reduced to 50% of the standard value, to achieve the purpose of reducing power consumption. The drive will automatically exit half current state when receiving new pulse.

◆ Offline Function

When inputting offline signal, the drive will cut off the motor phase winding current to make the motor shaft in a free state. At the moment the stepping pulse will not be responded to. This state can effectively reduce the power consumption and temperature rise of the drive and motor. The drive will automatically recover to the phase-sequence before offline and restore the motor current after the offline control signal undo. When need not this feature, the offline end dangles.

◆ Over-voltage Protection

When the power supply voltage fluctuations or motor brake and other reasons lead to the DC-bus voltage exceeds 45VDC, the drive alarm light is red, and the drive stop driving motor, and should power off and power on again manually, then removing alarm.





◆ Low-voltage Protection

When the drive detects that input DC bus voltage is below 10VDC, the drive alarm light is red, then cut off the motor winding output and stop running. You should power off and re-power on to remove alarm. After the fault appears, you need to check supply voltage and capacity, and increase input voltage appropriately.

◆ Functional Status Indicator

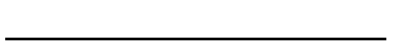
The yellow LED is power indicator. When the drive connects supply power, the LED lights. When the

drive is power off, the LED light is off. The red LED is malfunction indicator light. When the drive is failure, the indicator light off in different ways. The red LED represents different fault information by the bright light. The following table shows:

Red Light Blinking Mode	Red Light Blinking Waveform	Fault instruction
On		Over current alarm
Blink 2 times by 1 second		AD sampling midpoint wrong
Blink 3 times by 1 second		No connect the motor lines or motor lines is poor contact or winding short circuit
Blink 4 times by 1 second		Low-voltage failure (voltage<10V)
Blink 5 times by 1 second		Over-voltage failure (voltage>45V)

Control Signal

Common Terminal

The input signal of the driver uses a common anode connection way. The supply positive pole of the input signal should connect to the terminal. The input control signal is connected to the corresponding signal terminals. The control signal is effective for low level. This moment the corresponding internal optocoupler is connected, and the control signal is input to the driver.

Pulse signal input

In order to ensure the reliable response of pulse signal, the duration of the optocoupler effective conduction should not be less than $5\mu\text{s}$. The response frequency of the drive signal is 60KHz. High input frequency or sub-standard pulse width will not receive correct response.

Directional Signal Input

The terminal's high level and low level control the rotation of the motor. The terminal is dangling that means input high level. When controlling motor direction, you should ensure that the direction signal leading before pulse signal about $5\mu\text{s}$, and avoid the wrong response.

Off-line Signal Input

the motor phase current is off under the internal optocoupler conduction. The rotor is in a free state (off-line state). Optocoupler turns off, the motor current is restored to the size and direction before offline. When not use this feature, the offline signal terminal is unconnected. After the off-line signal is cancelled about $100\mu\text{s}$, the driver can receive the instruction pulse.

The drive terminal is pluggable terminal. You can unplug their first, and then plug wired.

Input Interface Circuit

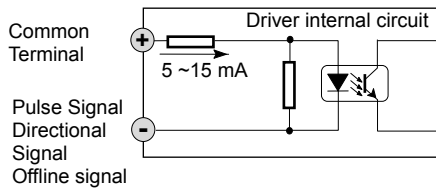

Note:

The interface can be adapted to TTL, OC, differential signal format.

The signal ports are adapted to +3V~24V voltage.

Input Signal Waveform and Timing

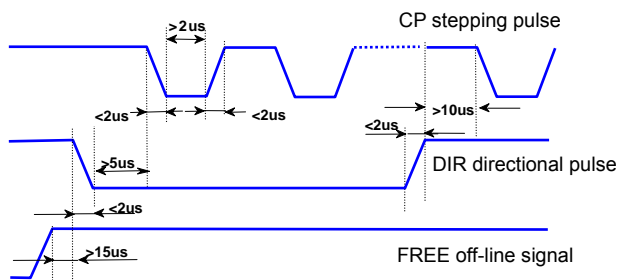

Wiring Diagram

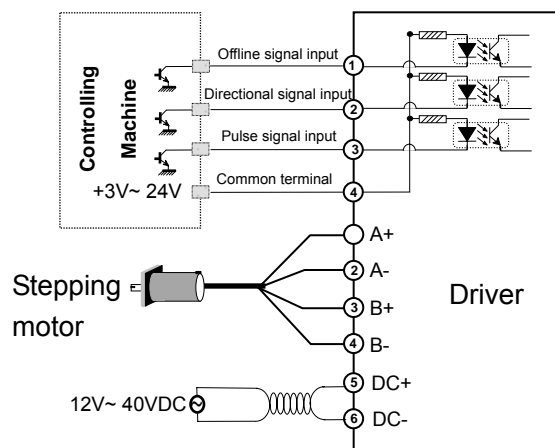

Dimension [Unit: mm]

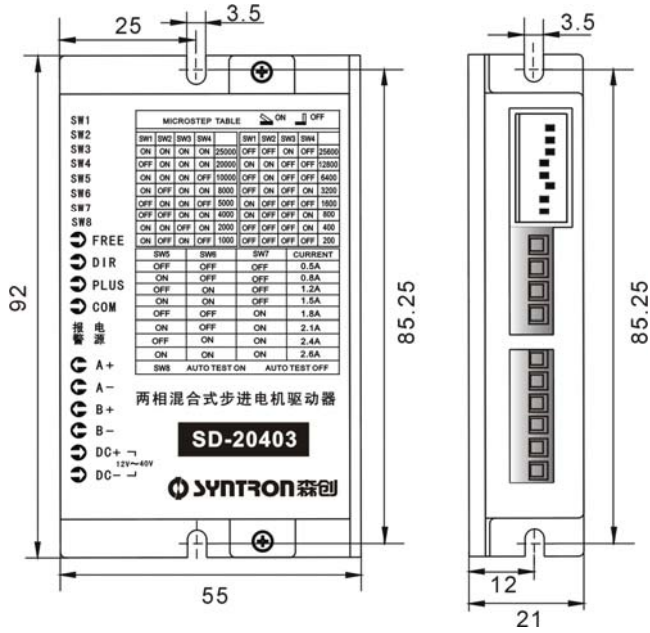

Products and services

Motion control motor and drive

◆ Stepping motor system

Two phase/three phase /five phase series

Motor diameter range: 28 mm ~ 130 mm

Motor torque range: 0.06 N·m ~ 45 N·m

Driver operating voltage range:

24VDC ~ 70VDC

100VAC ~ 220VAC

Driver output current range: 0.9A ~ 15A

Driver excitation modes: synchronism ~
128 subdivide

◆ AC servo system

Motor diameter range: 60mm ~ 190 mm

Power range: 200W ~ 7500W

Speed range: 1000 rpm ~ 3000 rpm

Torque range: 0.64 N·m ~ 71.6 N·m

◆ Brushless DC motor system

Motor diameter range: 57 mm ~ 92 mm

Power range: 70W ~ 600W

Speed range: 1000 rpm ~ 8000 rpm

Torque range: 0.095 N·m ~ 1.9 N·m

Driver operating voltage range: 48VDC ,
220VAC

High-speed brushless DC motor system

Power range: 200W ~ 1000W

Speed range: 10000 rpm ~ 20000 rpm

Torque range: 0.13 N·m ~ 1 N·m

Industry-specific control system

Digital winding cable control system

Electro-pattern-sewing control system

Pillow type packaging machine controller

Elasticizer ATTpw winding control system

Winding machine control system

Threading machine controller

Machine drive section

◆ Planetary reducer, linear motion section

Motion control system

◆ PLC, control cards, SC series controller, TRIO motion controller

Systems integration and services



Manufacturer: Beijing Hollysys Electric Technology CO., LTD.

Add: A-10F, HuiZhi Building, No.9 XueQing Road, HaiDian District

Beijing, 10085, China

Tel: (86)-10- 62932100

Fax: (86)-10- 62927946

http: www. syn-tron. com